

MODEL

212

WATERJET



**TURBO IMPELLER
OPTION AVAILABLE**

FOR TRAILERABLE CRAFT

HamiltonJet



GENERAL DESCRIPTION

The HJ212 waterjet is designed for a wide range of trailer-able boats. The HJ212 waterjet is a compact, high efficiency axial flow pumping unit which provides propulsive thrust which provides propulsive thrust from the reaction of the water jet stream. Mounted inboard at the stern, the jet draws water through an opening in the hull bottom, protected by a flush mounted screen. Projecting through a sealed opening in the lower transom, the pumping unit discharges water aft through the outlet nozzle.

STEERING

A trimmable JT type steering nozzle directs the jet stream to port or starboard for precise control. Control is via a push/pull cable system but a manual hydraulic system may be installed as an option.

REVERSE

A manually operated split duct astern deflector reverses the jet-stream. The deflector locks in any position between full ahead and full astern. By working the steering and reverse controls in unison, a resultant thrust can be obtained in any direction for 360 degrees thrusting ability, even at zero-speed.

ECONOMY

Since ahead, neutral and astern control is achieved by merely vectoring the jet stream, the jet can be direct driven by a range of marine engines. As well as saving the weight and cost of a gearbox, power loss through it is eliminated, improving performance and saving fuel.

COMPACT

Designed for close coupling of the engine nearer the transom, space within the boat is maximised. The steering/astern deflector arrangement reduces overhang beyond the transom.

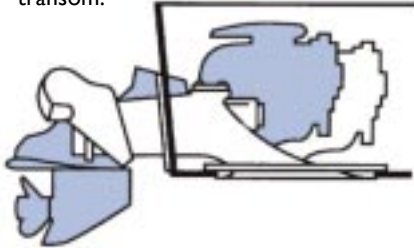

SIMPLICITY

As a single packaged module that replaces all individual components of conventional propulsion systems, engine alignment is simple and an inboard inspection hatch allows access to the interior of the jet. For routine servicing, the unit can be dismantled from outside the boat without disturbing the hull seal.



SCOPE OF USE

The HJ212 jet is designed for trailer-able craft. It is not suitable for craft permanently moored in salt water. Operation in the sea is perfectly acceptable but the jet should be flushed in fresh water after use (an alternative is the Hamilton HJ213 waterjet, which is designed with full cathodic protection for vessels permanently moored in salt water). Best efficiencies will be achieved in lightweight planing hulls designed for speeds over 25 knots. Monohedron shape (constant deadrise) with dead rise angle between 10°-30° is preferred.

STANDARD EQUIPMENT & SPECIFICATIONS

DESIGN	Impeller:	215mm (8.5") Single Stage
	Impeller Option:	'Fine'; 'Standard'; 'Coarse'; Extra Coarse (See back page for optional extra "Turbo" Impeller)
	Nozzle Options:	110mm
	Rotation:	Left hand (anti-clockwise looking at engine flywheel)
FEATURES	Thrust Bearing:	Angular Contact Ball Type
	Tail Bearing:	Water Lubricated Cutless Rubber Type
	Shaft Seal:	Face Type Mechanical Seal
	Transom Seal:	O-Ring Type
	Intake Screen:	Flush Mounted Steel Bar
	Inspection Hatch:	Inboard
MATERIALS	Mainshaft:	431 Stainless Steel
	Casing:	Cast LM6 Aluminium Alloy to BS 1490-1970
	Impeller:	Cast CF8M Stainless Steel to ASTM A743-80a
CONTROLS	Steering:	Balanced Steering Nozzle with Inboard Tiller for Manual Cable or Hydraulic system
	Reverse:	Split Duct type Deflector with Manual Push/Pull Cable Control
INSTALLATION	Transom Angle at Jet:	5° (+/- 3°)
	Close Coupling:	2 Stage Flexible Type plus Rear Engine Mount to suit Aluminium or GRP Hulls
	Installation Kit:	complete kit of nuts, bolts, washers etc plus Installation & Service Manual
WEIGHTS	Unit Weight:	70kg (less Coupling & Engine Mount)
	Intake Block:	7kg
	Entrained Water:	17kg (within the boat)

- Infinitely Variable Detent**
locks reverse deflector in any position
- Demountable Impeller Wear-ring**
permits easy maintenance
- Rear Borg Warner Type Engine Mount**
on jet for easy installation and alignment
- Large Thrust Bearing**
for long bearing life
- Intake Protection Screen**
fitted as standard

TYPICAL CRAFT PARAMETERS FOR SINGLE JET INSTALLATIONS

OVERALL LENGTH	MAXIMUM WEIGHT	POWER TO WEIGHT RATIO (MINIMUM)
6 - 8 M (20 - 26FT)	2.5 - 3 TONNES (2.4 - 2.9 TONS)	50Kw/TONNE (70HP/TON)

MULTIPLE JET INSTALLATIONS & OTHER HULL FORMS & SPEED RANGES ARE SUITABLE FOR WATERJETS

CONSULT HAMILTON JET FOR GUIDELINES

ENGINE MATCHING

Direct driven by a 4 to 8 litre (240 to 500cu.in) gasoline engine, the HJ212 jet will accept power inputs up to 260kW (350hp). The HJ212 jet is not recommended for direct match to a diesel engine – the alternative HJ213 jet is designed for diesel engines. Use the Power/RPM curves opposite to match the engine to the jet. Plot the maximum Power/RPM at the engine flywheel (or shaft if a gearbox is used) and choose the nearest impeller type from within the power envelope to give the best match. A reduction gearbox can be used to obtain the required power at matching revolutions but with consequential extra cost and efficient losses.

POWER/RPM CURVES – HJ212 STANDARD & TURBO IMPELLERS

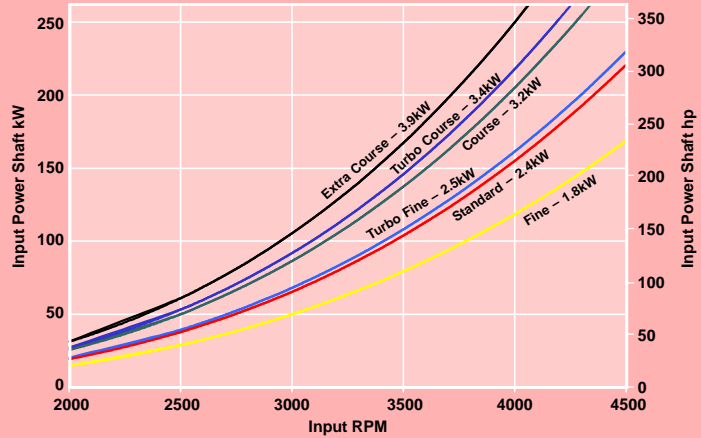

THRUST CURVE – HJ212 STANDARD IMPELLER

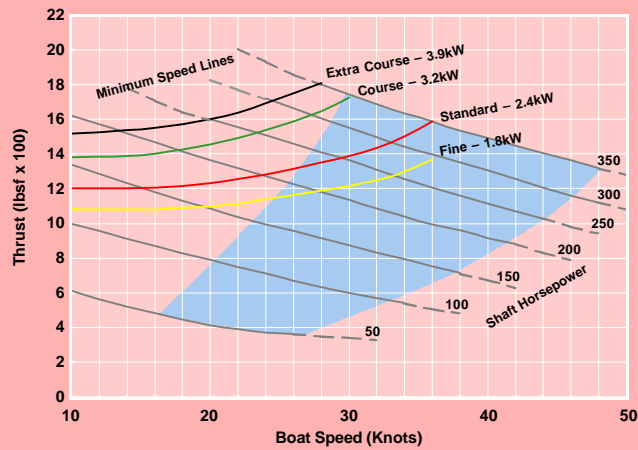

HIGH THRUST MARINE JET

Close Coupling Arrangement
for compact installation

O-Ring Transom Seal
for resistance to mechanical damage

Split Duct Deflector
for high efficiency reverse - has built in anti splash features eliminating the need for a splash guard



Aluminium Intake Block
standard for GRP and Aluminium hulls

Stainless Steel Impeller
standard or "Turbo" option available

JT type trimmable steering nozzle can be assembled so that jet stream exits at keel-line or at 5° below it - no extra parts required

MODEL **212**
TURBO
 IMPELLER OPTION



Whereas the standard HJ212 jet is only suitable for use where solid, unaerated water is presented to the jet intake, a turbo impeller is available as an optional extra on HJ212 jets.

Where craft are to operate effectively in broken white water, this advanced impeller design represents a significant development in terms of operational benefits. A single stage impeller with greatly extended blade area when compared to the standard HJ212 unit, the turbo impeller has been extensively tested in the field. Operations in grade 3 rapids showed the impeller to have superior performance characteristics.

Testing compared the turbo impeller with the standard HJ212 impeller. Results indicated the turbo impeller maintained its 'grip' in aerated water up to 50% longer than the standard impeller. When 'breakaway' does occur, the impeller exhibits excellent recovery characteristics. The turbo impeller is also suitable for high power applications where acceleration performance is important.

"TURBO" IMPELLER AND SAFETY IN AERATED WATER

The "Turbo" impeller has been developed with effective operation in whitewater in mind, but because of the risky and unpredictable nature of whitewater boating, Hamilton Jet can take no responsibility for the safety of boats fitted with this product when used in whitewater conditions. Good safe boating practice starts with the helmsman who must have suitable training and experience and who must ensure that the product and the boat are fit for the intended purpose.



OPTIONAL EQUIPMENT

- Turbo Impeller
- Inspection Hatch Extension
- Weed Rake
- Sand Trap Kit
- Flywheel Adaptor Plate
- 'H'-Bar Driveshaft
- Companion Flange

PERFORMANCE CHECK

Submit the following details to Hamilton Jet if computer analysis and speed prediction required –

- Waterline Length
- Maximum Chine Beam
- Maximum Laden Displacement
- Deadrise Angle (Midships & Transom)
- Required Speed (Maximum & Cruise)
- Proposed Engine(s) (Make/Model)
- Engine Max. Intermittent Rating (kW/rpm)
- Engine Max. Continuous Rating (kW/rpm)

ORDERING PROCEDURE

Please state the following when ordering –

- Single, Twin or Triple Installation
- Optional Equipment Required
- Proposed Engine(s):
 Make/Model
 Maximum kW/rpm (hp/rpm)
- Hull Construction:
 GRP/Wooden
 Aluminium
 Other

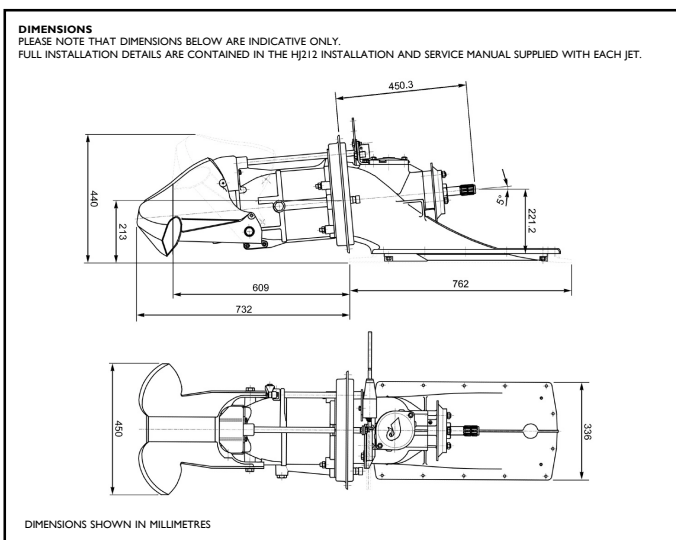

YOUR AUTHORISED HAMILTON JET DISTRIBUTOR IS:

SPECIFICATIONS IN THIS PUBLICATION ARE SUBJECT TO CHANGE WITHOUT NOTICE OR OBLIGATION

